



## Variable speed drives for Propulsion

Diesel - Electric

### Technical specifications

Variable speed drives for Propulsion	
<b>EVE-frequency converter</b>	(Detailed information available on our website www.eekels.com)
Max. Motor power	2,6MW
AC Supply voltage range	400-690V / 6 pulse or low-harmonic (12-pulse, AFE, filter)
DC Supply voltage range	560-975V
Frequency range	0-100,00Hz / 0-200,00Hz
Efficiency	Higher than 98%
Cooling method	Both water- as air-cooled are available
Communication	Profibus-DP, MODBUS-RTU, Ethernet TCP/IP
Interference protection	IEC 61800-3 (EN 55011 optional)
Certification	According class bureau: BV, LRS, ABS, etc.
<b>Standard E-motor</b>	
Protection class	IP 54 or ATEX certified
Thermistor protection	PTC's
Anti condensation heating	Yes

Eekels can deliver frequency converters in the range of 5,5 kW up to 2,6 MW.

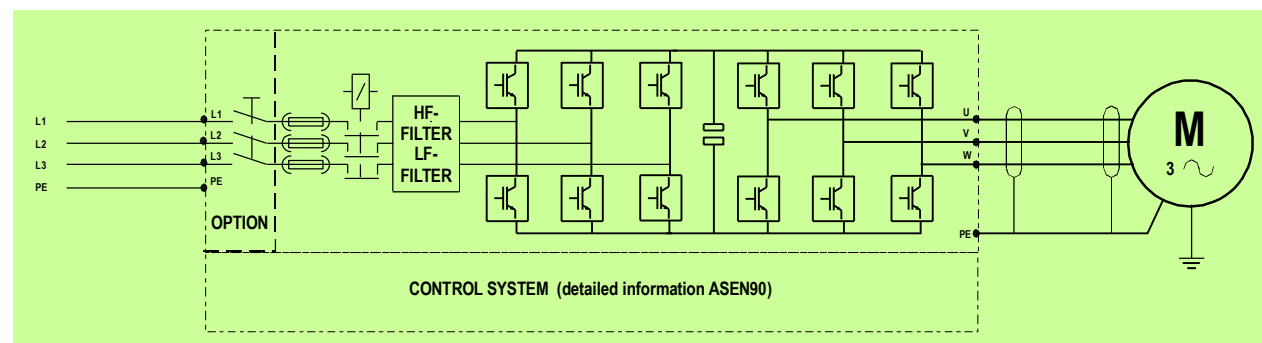

Schematic of a Active Front End frequency converter

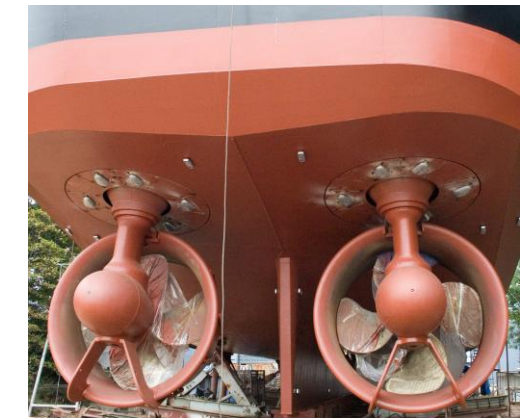

#### Characteristics of the Propulsion System

- Power up to 2,6 MW
- Low Harmonic (12-puls, harmonic filter, Active Front End)
- 4 quadrant operation for optimal system dynamics (AFE)
- Standard motor (IP54 or ATEX certified)
- DC-braking
- Exact torque and speed control without the need of feedback devices.
- Reliable
- Easy to control
- Minimal interface cabling because of the bus concept
- Interface for Power Management System
- VDR output (Voyage Data Recorder)

Eekels has over 30 years of experience in developing and manufacturing frequency converters. Eekels is also well known in developing ship installations, drives for propulsion bow and stern thrusters.

The propulsion system is the most important system aboard any ship. This system consists of main drives and/or bow thrusters to enable the safe and efficient maneuvering of the ship. By using diesel-electric propulsion a high degree of flexibility, efficiency and redundancy is achieved.

The EVE frequency drives make it possible to adjust the speed and direction of the propellers with maximum torque and efficiency at any speed. Due to the modular design and easy control logic, the EVE frequency converters are ideal for DP-2 (Dynamic Positioning) or higher class ships.



#### Other marine drive applications:

- Cargo pumps
- Cargo fans
- Cranes
- Winches
- Bow and Stern thrusters
- Bi-directional supply units and choppers Soft starters

# Diesel Electric Propulsion Options

Three different concepts

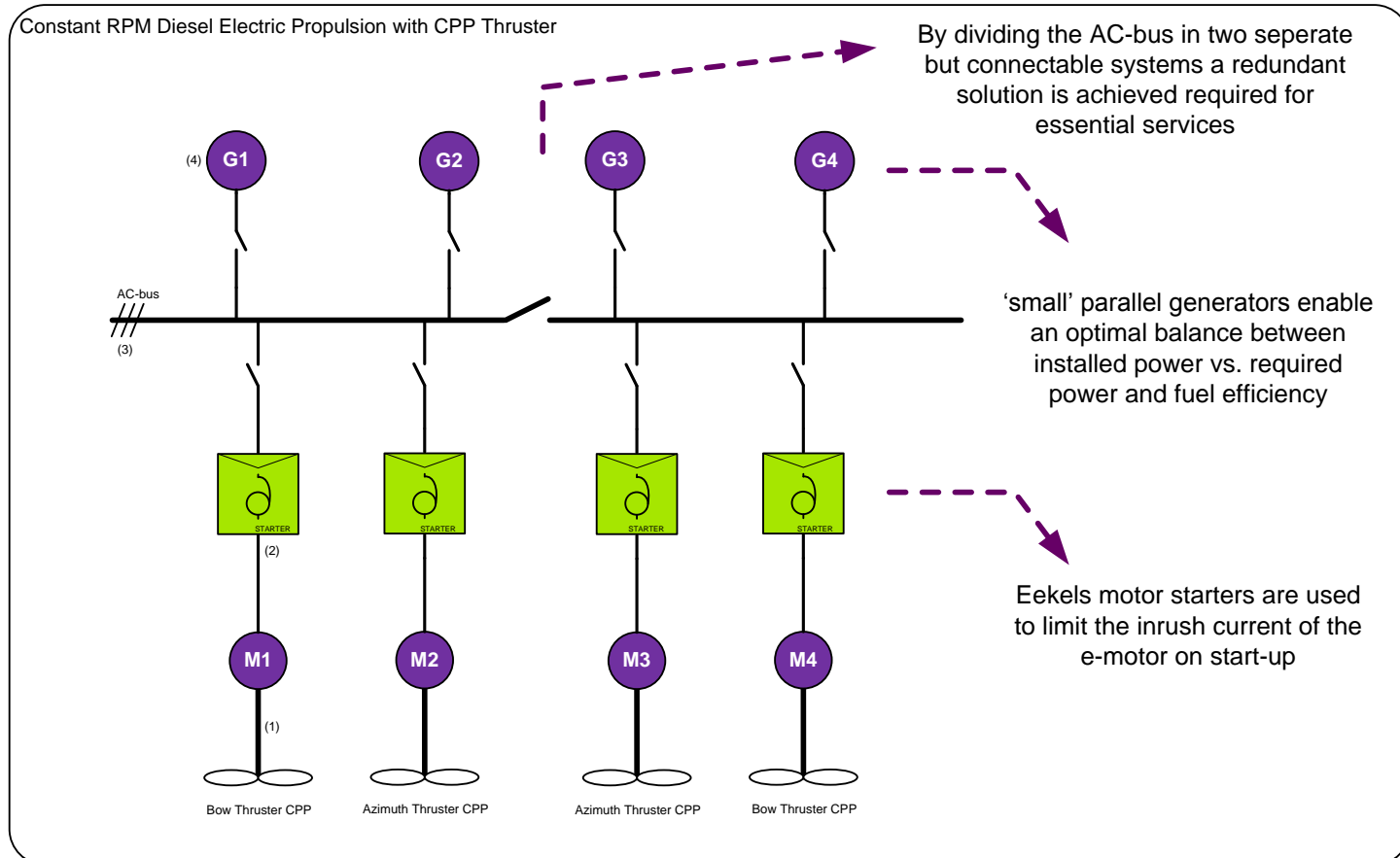
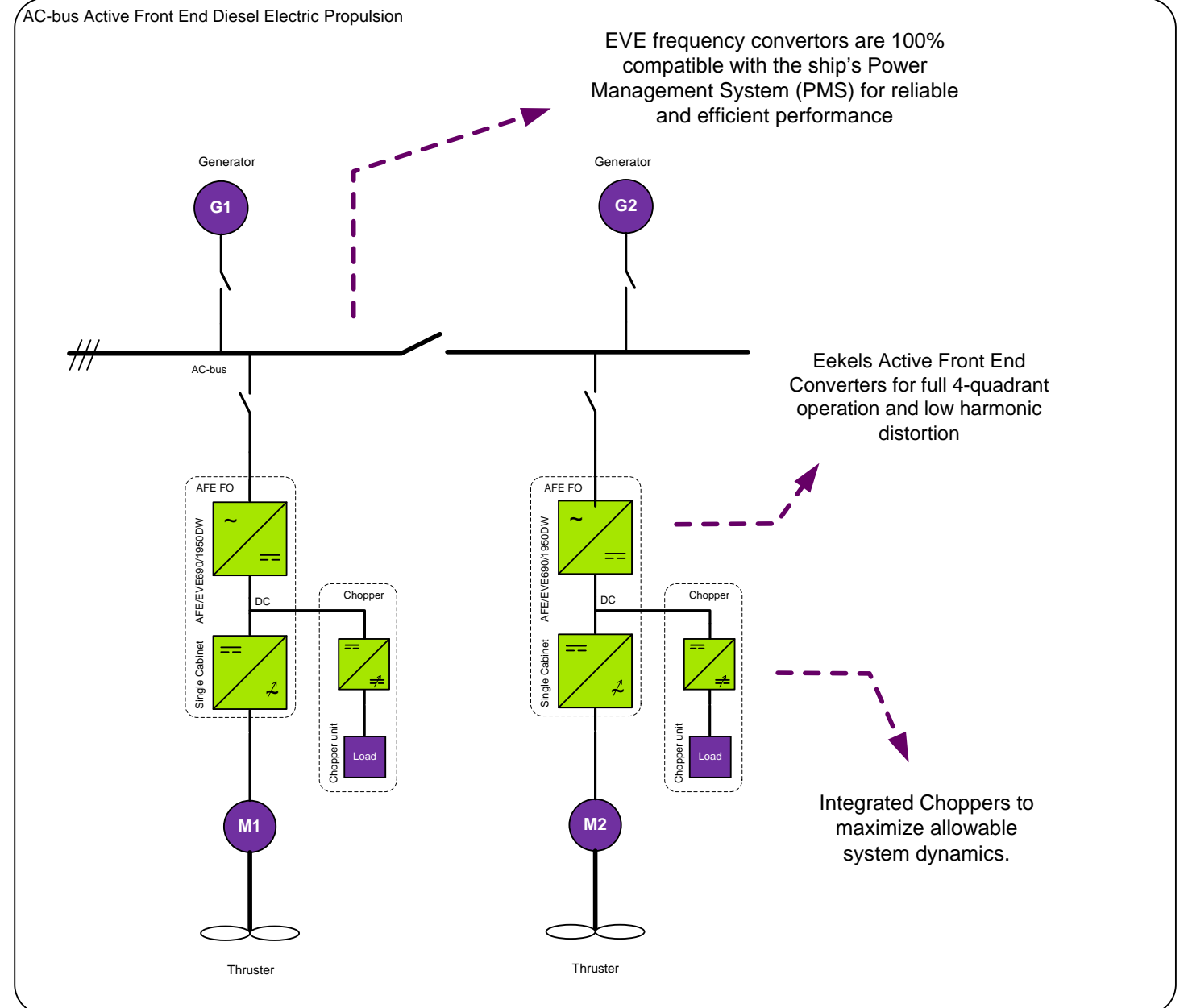
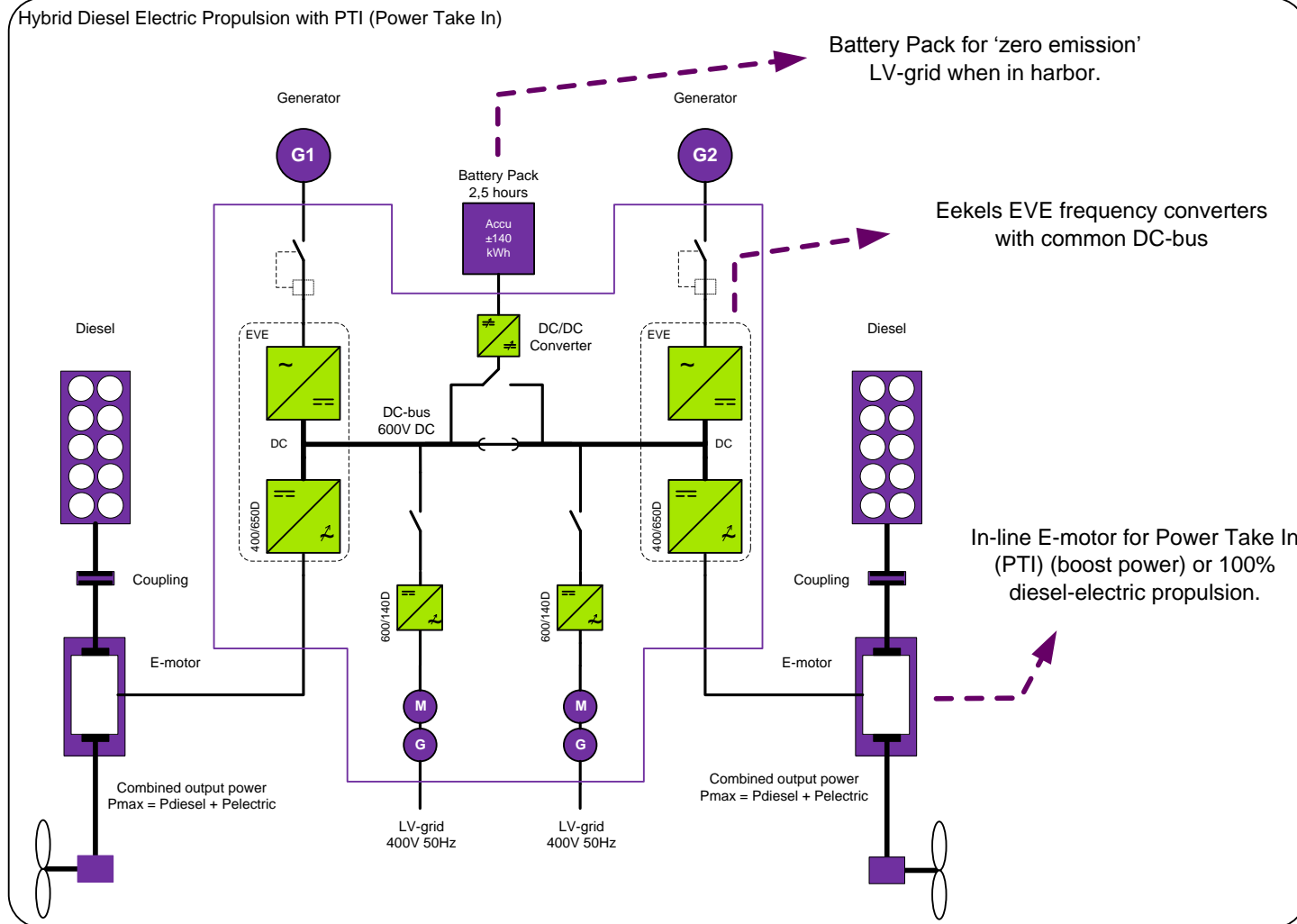

## Key Features:

- Flexibility
  - Component placement
  - Hull Design
- Optimal load balancing
  - High Power Factor (Freq. drive)
  - Integration with PMS
- Accurate thrust control
- High efficiency during high load variances (Freq. drive) (e.g. Dynamic Positioning)